

Adaptive's Industrial Automation Platforms are pre-configured industrial manufacturing cells and equipment available for customization. These platforms are a fraction of the price of a custom automation solution, and available in less than half the time. These engineered and proven platforms reduce workload project risk, allowing your team to achieve more, faster.

The IAP-Packflow is a pre-configured case form, fill, and seal cell. Using a 6-axis robotic arm equipped with advanced tracking and machine vision guidance, this highly flexible solution is capable of locating and picking parts from a moving conveyor and placing them into formed cases. Filled and sealed cases are then returned to the conveyor or sent out of the cell on a secondary conveyor. The base system includes a Fancu M10iD/12 6-axis robotic arm mounted to a welded steel pedestal, Fancu IR machine vision and advanced line tracking, a case former, case sealer, electrical enclosure, PLC control system with color touchscreen HMI, and complete safety system. Engineered and designed for continuous operation, this extremely robust platform can be tailored to accommodate many packaging operations.

All product tooling (fixtures, robot end of arm tools, part feeders, etc.) and any additional station equipment is the responsibility of the end user. All software development and testing (PLC, robot, HMI, etc) programming is the responsibility of the end user.

Available Options & Add-ons Base Machine Features:

- Change robot model for different payload/reach.
- Change case erector/case sealer to accommodate different case forms/speeds.
- Add laser, ink, or print & apply case labeling.
- Add case band strapping.
- Robot Touch Tooling (EOAT)
- Machine Vision & Lighting
- Part Feeding & Escapement
- Conveyance into/out of cell
- Operator Push Button Controls
- Ignition SCADA Software
- Remote Access Module
- Work Fixtures & Nests
- Programming Support (robot, vision, PLC, HMI)

- Welded steel robot pedestal and Fancu M10iD/12 robotic arm
- Welded steel stand and Fancu IR Vision station
- Powered belt conveyor with pulse encoder for inbound product.
- Case/tray forming equipment with magazine feeder.
- Hot-melt glue applicator and case/tray sealing equipment.
- Powered belt conveyors for in-cell case handling and outbound cases.
- Electrical enclosure with PLC, 24V Power Supply, and Safety PLC.
- Full safety system (floor mounted safety enclosure with interlocked gates, safety PLC, dump valve, E-stop buttons)
- 3-Light stack indicator.
- Web Browser programming interface.
- Pneumatic air prep & valve bank.

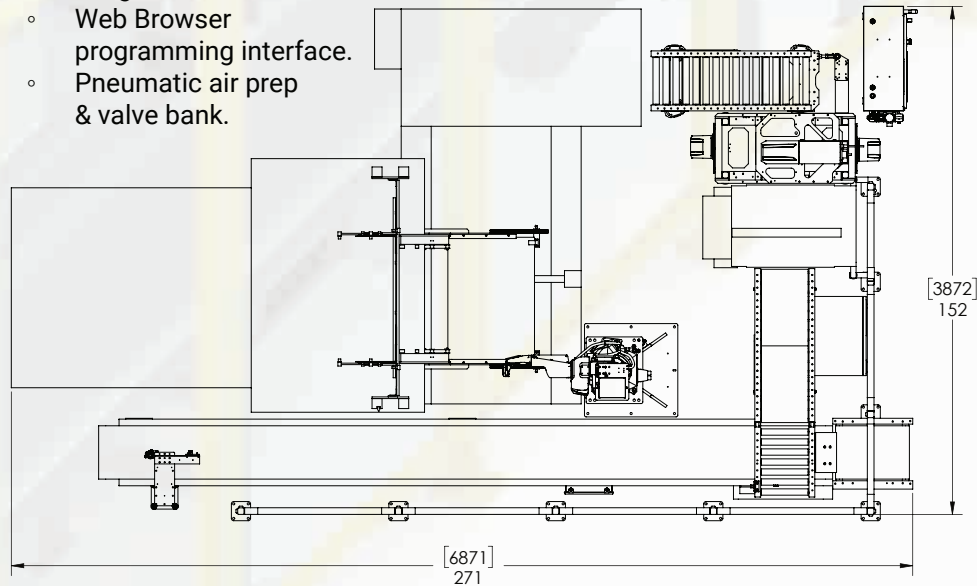

	Base Unit Specifications	Notes
Cycle time starting at	3 seconds	
Machine Footprint	271" x 152"	includes enclosure
Machine Height	8 ft	includes safety frame at 36" infeed height
Machine Weight	Based on case former selection	
Infeed conveyor height	30" - 36"	
Max Product Size	17.5" x 22" x 3"	
Max Product + EOAT Weight	25 lbs	
Voltage	480V, 60Hz 3PH	
Air	80-100 psi	